



PERSHING COUNTY BUILDING DEPARTMENT BUILDING GUIDE

Single Family Residential Addition

How to use this guide:

At least three completed documents must be provided to apply for a building permit:

1. Complete this guide by filling in the blanks on page three, indicating which construction details will be used. Please print legibly.
2. Provide a separate site plan showing dimensions of your project or addition and its relationship to the existing building or structures on the property. Show all easements and the distance to existing property lines.
3. Provide a floorplan.
4. Envelope compliance forms to meet IECC 2012. This is a summary of your wall, window, and door areas and insulation values.
5. Fill out a building permit application.

The majority of permit applications are processed with little delay. The submitted documents will help determine if the project is in compliance with building safety codes, zoning ordinances, and other applicable laws.

Heads up:

Site Plan

1. When drawing your site plan, be sure to show the location of electric, gas, sewer, and water service lines.
2. Show where the existing electric and gas meters are located on your home. These meters may have to be relocated, and it is best to know this before you start construction.

Floor Plan

1. If the value of your addition exceeds \$1,000, the Uniform Building Code asks you to add *smoke detectors* to your home. Battery-operated smoke detectors will do the job in existing areas. At least one on each level of your home, one in each bedroom, and one in the area(s) serving the bedrooms are required.
2. Landings are required at exterior doors. The landing may be as much as eight inches lower than the floor of the room. It must be at least a minimum of 3'-0" x 3'-0". There is no limit as to how large it can be.
3. Safety glass is required at specific locations. When you draw in the location of the new windows on the floor plan, the plan reviewer can identify which one(s) require safety glass.
4. Heat is required in all habitable rooms. Show how the addition will be heated on the plan.

Electric Code

1. Existing electric service may require an upgrade or relocation. Indicate the size of your existing electric service (the number on the main breaker) on your plan. This can help the plan reviewer determine if an upgrade is needed before you start construction.

Roof Overframe

1. When constructing a new valley, use a continuous board under the bottom cut of the new rafters to provide a solid nailing surface. The board should be at least 1" thick, nominal and should be at least as wide as the base of the new rafter.

Crawlspace Foundation Detail A

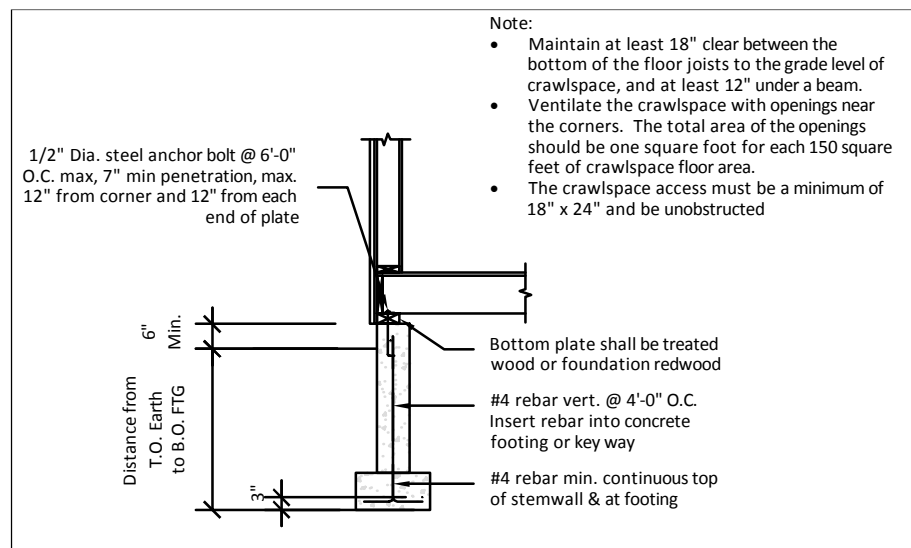



PERSHING COUNTY BUILDING DEPARTMENT BUILDING GUIDE

Single Family Residential Addition

Sample Floor Plan:

Note:

- A. New 3'-0" x 6'-8" door in existing wall
- B. Existing door removed, opening covered with drywall both sides
- C. New 5'-0" x 4'-0" cased opening (replaces existing window)
- D. New patio door with tempered glass
- E. New 6'-4" x 4'-8" casement windows

General:

- (2) 2x10 headers at new window and door openings

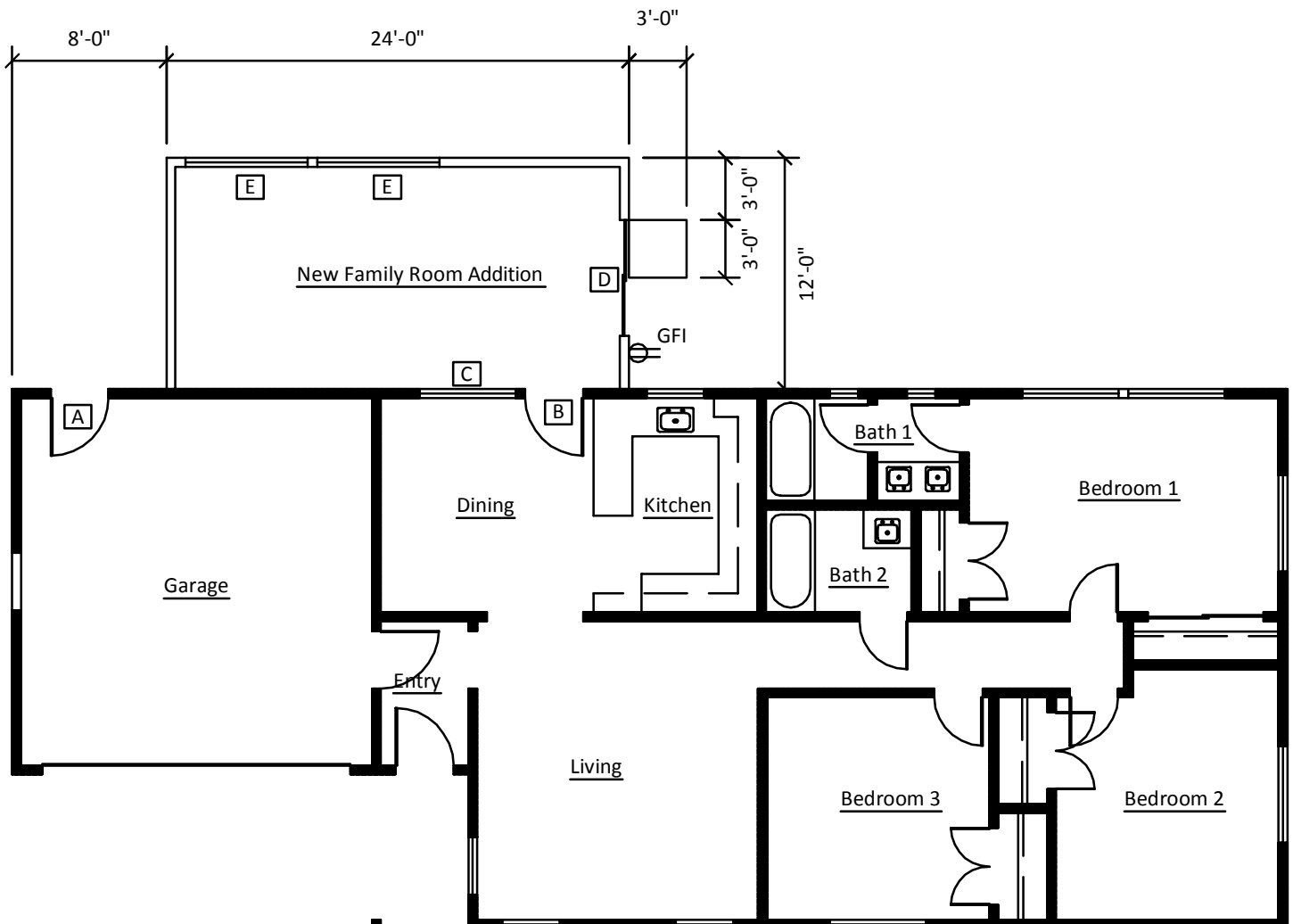



PERSHING COUNTY BUILDING DEPARTMENT BUILDING GUIDE

Single Family Residential Addition

Building Section:

Property Address: _____
Permit # _____

Inspections

Please contact the Pershing County Building Department to have the following phases of construction inspected:

1. Rough in of footings prior to concrete work. _____
Insp. Date _____
2. Framing and structural work prior to cladding. _____
Insp. Date _____
3. Insulation, Mechanical, Electrical Plumbing rough. _____
Insp. Date _____
4. Finish and Final on work and Utilities. _____
Insp. Date _____

