



PERSHING COUNTY BUILDING DEPARTMENT BUILDING GUIDE

Single Family Residential Detached Garage

Building Guide

Directions

1. Complete this Building Guide by filling in the blanks on page two and three, indicating which construction details will be used below.
2. Provide a floor plan (site plan) showing dimensions of your project or addition and its relationship to existing buildings or structures on the property, and the distance to existing property lines.
3. Fill out a building permit application.

The majority of permit applications are processed with little delay. The submitted documents will help determine if the project is in compliance with building safety codes, zoning ordinances, and other applicable laws.

Foundation Details

Foundation Detail A

Note: Check with Building Department for swelling soils. Cassons may be required

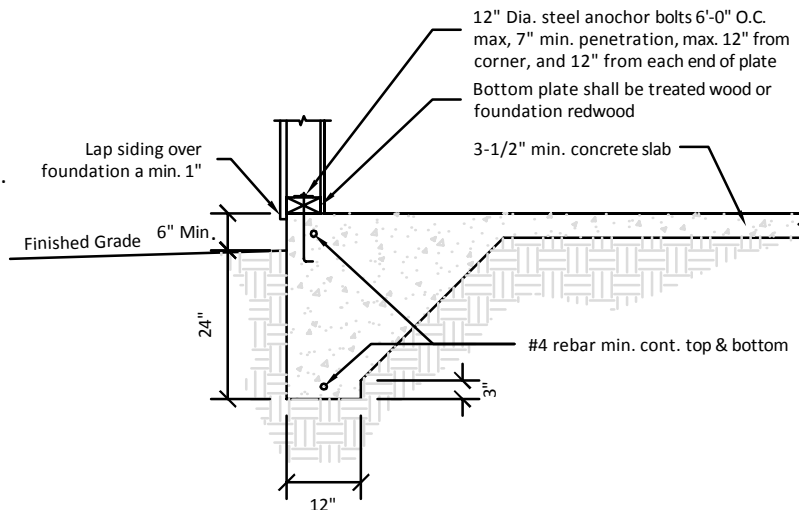

Foundation Detail B

Note: Check with Building Department for swelling soils. Cassons may be required

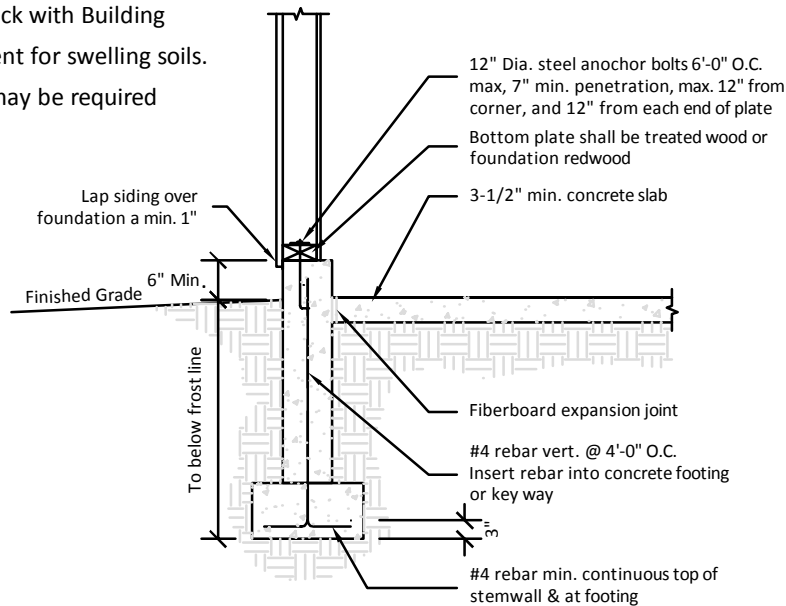



**PERSHING COUNTY BUILDING
DEPARTMENT BUILDING GUIDE**

Single Family Residential Detached Garage

Floor Plan

Property Address _____

Permit# _____

Directions

1. Fill in the blanks on pages two and three with dimension and materials which will be used to build the structure. Please print legibly.
2. Show door and window header sizes and location.
3. Show size of landing in front of door(s).
4. Indicate in the check boxes on page three which detail from page 4 will be used.

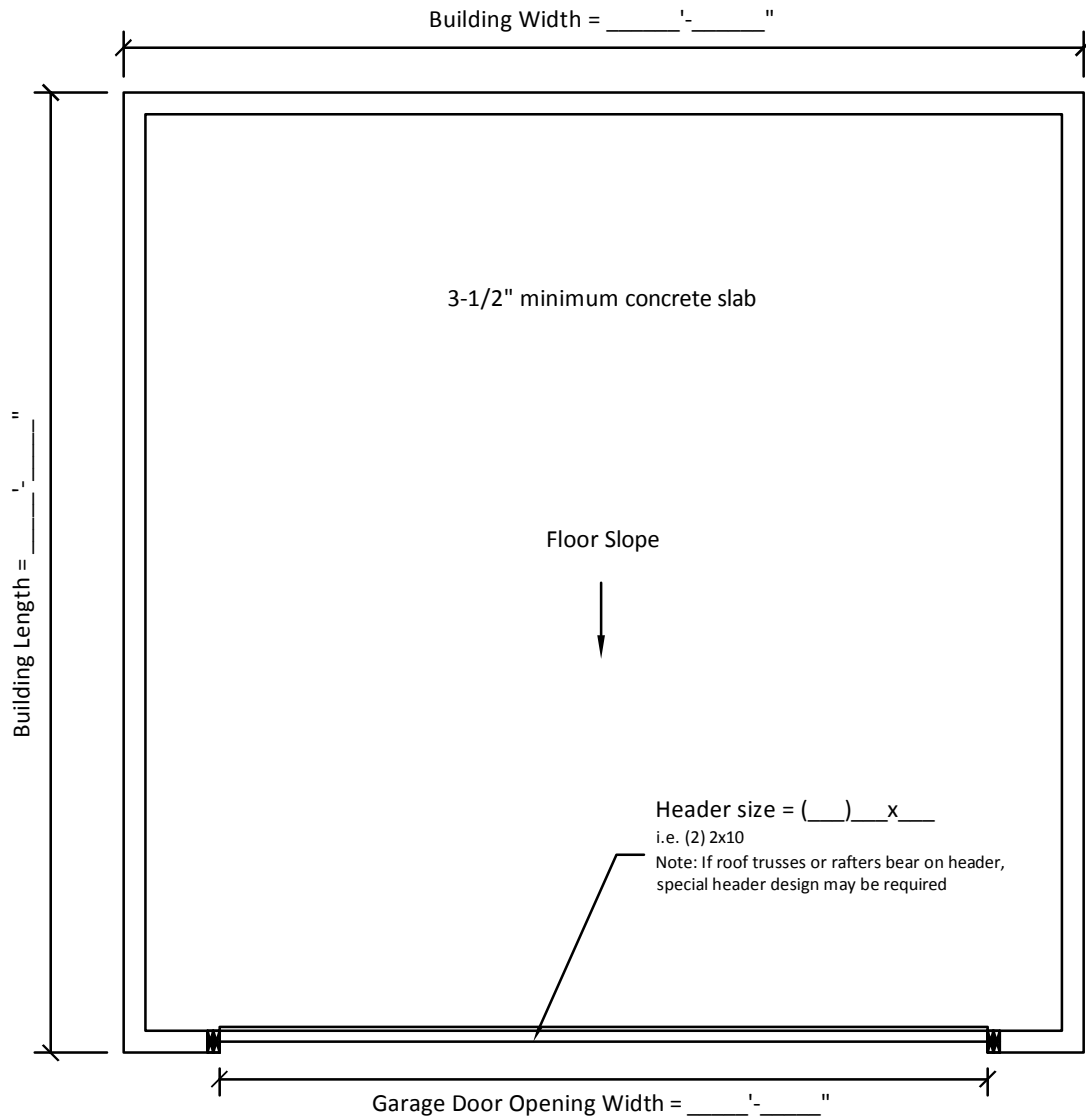



PERSHING COUNTY BUILDING DEPARTMENT BUILDING GUIDE

Single Family Residential Detached Garage

Building Section

Property Address _____
Permit# _____

Note: Roof not to exceed 24'-0" span

Inspections

Please contact the Pershing County Building Department to have the following phases of construction inspected:

1. Rough in of footings prior to concrete work. _____
Insp. Date _____
2. Framing and structural work prior to cladding. _____
Insp. Date _____
3. Insulation, Mechanical, Electrical Plumbing rough. _____
Insp. Date _____
4. Finish and Final on work and Utilities. _____
Insp. Date _____

